

Part number:

HYDROMA
HYDRAULICKÉ SYSTÉMY

HIDROMA
SYSTEMS
UKŁADY HYDRAULICZNE

HYDROMA
ГИДРАВЛИЧЕСКИЕ СИСТЕМЫ

RV10-22

RELIEF VALVE CARTRIDGE DIRECT ACTING POPPET

Overview

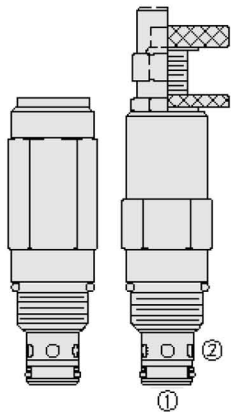

Description

RV10-22X is a screw in, cartridge style, direct acting, differential area, poppet type hydraulic relief valve intended for use as a pressure limiting device in more demanding hydraulic circuits requiring low hysteresis and low internal leakage.

Operation

The RV10-22X blocks flow from port 2 to port 1 until sufficient pressure is present at port 2 to force the poppet from its seat. The cartridge offers smooth transition in response to loads in common hydraulic circuits.

Features

- Adjustments cannot be backed out of the valve.
- Adjustments options A, B, and C: positive stops prevent springs from going solid.
- Hardened poppet and cage for long life.
- Optional spring ranges to 241 bar (3500 psi).
- Rapid response to pressure surges.
- Industry-common size.

Symbol

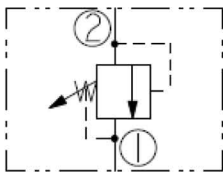

Ratings

Pressure Ratings

Pressure rating	241.3 bar (3500 psi)
Proof pressure	482.6 bar (7000 psi)
Burst pressure	965.3 bar (14000 psi)
Relief pressure defined	Pressure evident at 0.95 lpm (0.25 gpm)

Flow Ratings

Flow rating	113.6 lpm (30 gpm)
Maximum internal leakage	5 drops/min - Note: To 85% of nominal setting

Temperature Ratings

Operating fluid temperature	-40 to 100 °C (-40 to 212 °F)	- Note: With buna N seals
	-26 to 204 °C (-15 to 400 °F)	- Note: With fluorocarbon seals
	-54 to 107 °C (-65 to 225 °F)	- Note: With polyurethane seals
Storage temperature	-40 to 70 °C (-40 to 160 °F)	
Ambient temperature	-40 to 70 °C (-40 to 160 °F)	

Other Ratings

Corrosion protection	GRV10-22X 960 hr salt spray per ASTM b117
----------------------	---

Operating Parameters

Fluids	Mineral based or synthetic hydraulic fluid with lubricating properties
Fluid viscosity range	7.4 to 420 cSt
Maximum operating contamination level	18/16/13 per ISO 4406

Properties

Unit weight	0.231 kg (0.51 lb)	- Note: RV10-22A
	0.254 kg (0.56 lb)	- Note: RV10-22B
	0.276 kg (0.61 lb)	- Note: RV10-22C, RV10-22L
	0.222 kg (0.49 lb)	- Note: RV10-22F, RV10-22H
Internal wetted surface area	114 cm ² (17.7 in ²)	- Note: A, B, C and L
	126 cm ² (19.5 in ²)	- Note: F and H

Performance

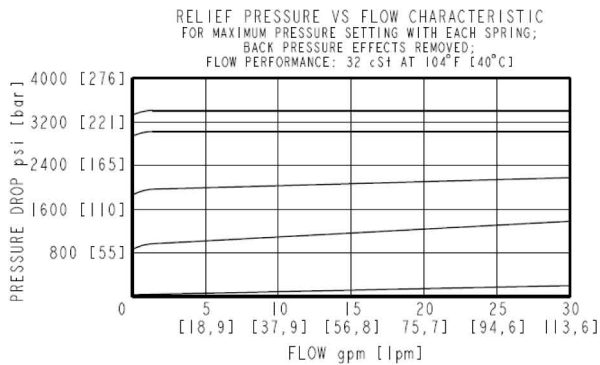

Dimensions

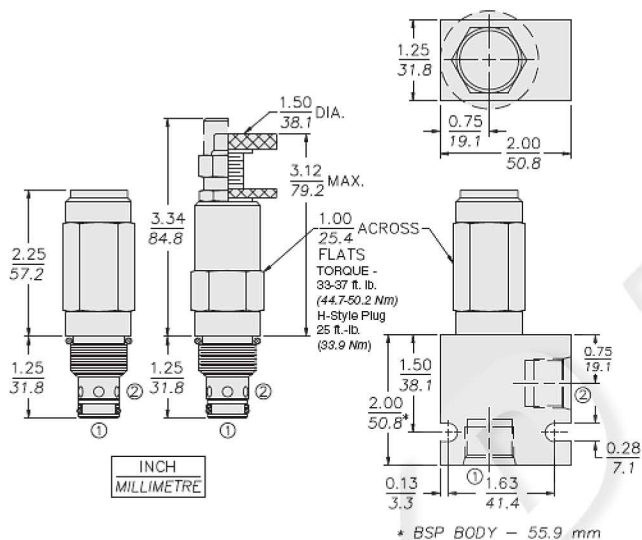

Installation Specifications

Cavity	VC10-2
Cartridge installation torque	33.9 to 36.7 N-m (25 to 27 ft-lb) 66.7 N-m (50 ft-lb) - Note: Maximum allowable
Adjuster cap torque	32.5 to 35.3 N-m (24 to 26 ft-lb) - Note: H-style plug
Orientation restriction	None

Accessories

Seal kit	SK10-2X-T	- Note: X = N, V, P
	SK10-2X-M	- Note: For bidirectional operation
	SK10-2X-O	- Note: X = U

Order Code

ORDERING INFORMATION:
XR10-22X-X-XX-XX/XXXX

PROTECTION OPTION:

STANDARD PLATING - OMIT
960 HOUR PROTECTION - G

BASE MODEL NUMBER:

ADJUSTMENT OPTIONS:

0.25 [6,4] HEX ALLEN HEAD - A
Ø1.50 [38,1] ALUMINUM KNOB - B
OPTION "A" WITH COVER CAP - C
FACTORY PRESET NONADJUSTABLE - F
FACTORY PRESET HIDDEN ADJUSTMENT - H
OPTION "C" WITH LOCK WIRE HOLES - L

PORTING:

CARTRIDGE ONLY - 0

SEAL OPTION:

PRESSURE ON PORT 2 ONLY
BUNA N - N
FLUOROCARBON - V
POLYURETHANE - P
URETHANE - U
BIDIRECTIONAL PRESSURE
BUNA N - NC
FLUOROCARBON - VC
POLYURETHANE - PC

SPRING RANGE:

100 TO 600 psi - 06
[6,9 TO 41,4 bar]
150 TO 1300 psi - 13
[10,3 TO 89,6 bar]
250 TO 2500 psi - 25
[17,2 TO 172,4 bar]
300 TO 3500 psi - 35
[20,7 TO 241,3 bar]

PRESSURE SETTING:

FOR EXAMPLE:
(IN psi)
3500 psi - 35
(IN bar)
150 bar - M150**Model Options****RV10-22F-H-J-R/S****F Adjustment Option**

CODE	DESCRIPTION
A	1/4" Hex Allen Head
B	1-1/2" Diameter Aluminum Knob with Aluminum Lock Knob
C	1/4" Hex Allen Head with Cover Cap
F	Factory Preset Non-Adjustable
H	Factory Preset Hidden Adjustment
L	1/4" Hex Allen Head with Cover Cap and Lockwire Holes

H Line Body

CODE	DESCRIPTION
0	No Body
6T	Aluminum SAE 6
8T	Aluminum SAE 8
6TD	Ductile Iron SAE 6
8TD	Ductile Iron SAE 8
2B	Aluminum BSPP 1/4" (2)
3B	Aluminum BSPP 3/8" (3)
4B	Aluminum BSPP 1/2" (4)
4BD	Ductile Iron BSPP 1/2" (4)

J Seal

CODE	DESCRIPTION
N	Buna-N
NC	Buna-N for Crossover Applications

CODE	DESCRIPTION
V	Fluorocarbon
VC	Fluorocarbon for Crossover Applications
P	Polyurethane
PC	Polyurethane for Crossover Applications
U	PPDI Urethane

R Spring

CODE	DESCRIPTION
06	6.9 to 41.5 bar (100 to 600 psi) Spring Range
13	10.3 to 89.6 bar (150 to 1300 psi) Spring Range
25	17.2 to 172.4 bar (250 to 2500 psi) Spring Range
35	20.7 to 241.3 bar (300 to 3500 psi) Spring Range

S Setting

CODE	DESCRIPTION
MXXX	Spring Setting in XXX bar
XX	Spring Setting in XX psi (x 100)